

# HEATER OPEN ALARM

FAL-100-1 P/Z Single-phase  
 FAL-100-3 P/Z 3-phase

Specifications  
 Instruction Manual

	Phase control	Zero cross control
Single-phase	FAL-100-1	FAL-100-1
Three-phase	FAL-100-3P	FAL-100-3Z



Forest Co.,Ltd.

## Heater Open Alarm

Model: FAL-100-1 (Single-phase) FAL-100-3 (3-phase)

**Features:** High-precision operation is possible because of automatic load setting by microcomputer processing. The alarm point is digitally set, permitting easy setting without personal difference.

**Principle of operation:** Microcomputer processing is conducted so that the normal heater current will be 100%, and the current reduction ratio (normal value % - present value %) is compared with the value set in the alarm. When the reduction rate exceeds the preset value, an alarm is output. This unit simultaneously takes in the voltage applied to the heater in order to convert the heater current into the value at the rated voltage at all times even if the voltage drops. Accordingly, normal monitoring is possible even in cases where the heater voltage drops and the current reduces, permitting use for phase control. However, disconnection monitoring is conducted when the heater voltage is more than 15% of the rating, stopping operation when the heater voltage is less than 15%.

### Specifications

**Power for instrument:** 100~220VAC ±10%; 50/60Hz  
**Heater capacity:** Direct coupling when less than 0.5kW for 100 VAC and 1.0kW for 200VAC (load current: less than 5A)  
 When the capacity exceeds the above, use the alarm in combination with external C,T.  
 \*Use external C,T irrespective of the rated capacity in the case of the 3-phase (FAL-100-3) type.  
 (The maximum current taken into the alarm is 5A.)  
**Detection input:** Load current and load voltage.  
**Load setting range:** Automatic load setting between 1.0 and 5.0A.  
 \*An alarm for 0.5~2.5A can be manufactured as an option.  
**Alarm setting range:** 0~30% (Alarm set value: 0~15×2); Set by means of the current reduction rate.  
**Load setting accuracy:** ±3%  
**Alarm setting accuracy:** ±3%  
**Alarm output:** Relay contact output: 200VAC; 1A; 1ab(load resistance)  
 LED display (Red)  
**Insulation resistance:** 50MΩ or more(500VDC meg ohm meter) between respective input terminals  
**Withstand voltage:** 1500VAC/minute between respective input terminals  
**Operating environment condition:** Ambient temperature...0~50°C  
 Ambient humidity...90%RH or less(There is no dew condensation)  
**Shape:** Plug-in type to be installed in panel(The base socket is not accompanying. ...OMRON 11PFA or its equivalent)  
**Weight:** FAL-100-1...300 g; FAL-100-3...350 g

### Front panel drawing

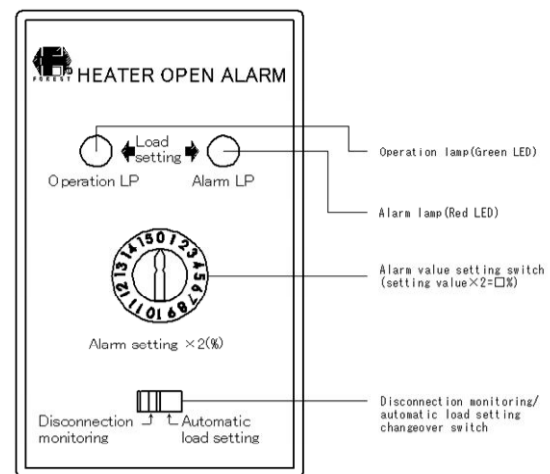

### Appearance dimension drawing

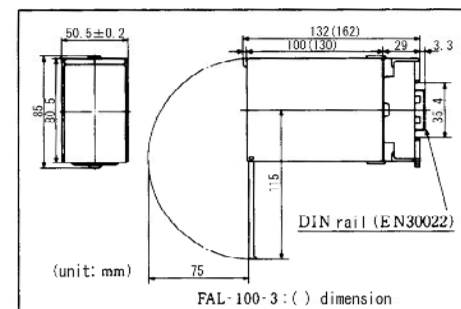

### Panel mounting dimensions

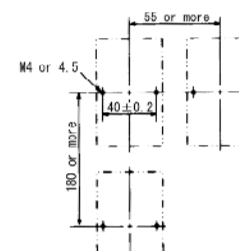

### Setting method:

- When the specified connection is completed, supply electricity normally to the instrument power supply and heater load, and set the alarm after setting the stabilization time (more than 3 minutes).
- Current setting (Automatic load setting)**  
 When the heater is normally operated, operate the disconnection monitor/automatic load setting changeover switch (hereinafter called the changeover switch) to detect and store the load status.  
 During load setting, the alarm LP and operation LP blink alternately.  
 When the alarm is operated for the first time after installation or after the heater is changed, be sure to set the load.  
**Operation 1:** Conduct normal operation of the alarm, and shift the disconnection monitor ↔ automatic load setting changeover switch at the front panel to the automatic load setting side. At that time, the operation LP and alarm LP blink alternately, and the alarm is ready for automatic load setting.  
**Operation 2:** Shift the changeover switch to the disconnection monitor side. Approx. 10 seconds after the shift, the operation LP and alarm LP stop blinking, and either the operation LP or the alarm LP comes on. (When the alarm setting is 0%, the alarm LP comes on.)  
 Now the current setting is complete.
- Alarm setting**  
 Adjust the alarm setting switch to set the current reduction rate (%) with respect to the normal heater current, at which an alarm is to be given  
 For example, an alarm will be given if the heater current reduces by 2% (1 × 2 = 2) when 1 is set and when it reduces by 8% (4 × 2 = 8) when 4 is set.  
 When the setting is below 4%, an alarm may be given by mistake because of the heater temperature coefficient error or the instrument error.  
**Example of setting:** A set value to give an alarm when one of five heaters (connected in parallel) is disconnected ... Current reduction rate when one is disconnected ... 1/5×100 = 20%  
 When the alarm setting switch is set at 8 (8 × 2%) = 16% An alarm is given.  
 When the alarm setting switch is set at 9 (9 × 2%) = 18% An alarm is given.  
 When the alarm setting switch is set at 10 (10 × 2%) = 20% An alarm may not be given in some cases.
- Alarm response time**  
 When the current reduction beyond an alarm setting value occurs from normal operation, an alarm output does not come out immediately.  
 When [ of about 10 seconds ] it delay-time (calculation of a taking-in-data value)-back-answers and abnormalities are checked, an alarm output is carried out until it carries out an alarm output.  
**Attention**  
 If the operation power supply of a heater disconnection alarm is in the state of ON when the control output after alarm output generating is cut off, an alarm output will be held as it is.  
 Please perform the normal check of load to see you make an operation power supply turn off once, when an alarm output wants to return.
- Monitoring action**  
 Monitoring is conducted when the heater voltage is more than 15% of the rated voltage, and it stops when the heater voltage is below that.  
 An alarm is given when the heater current reducers in excess of the set value (%), and it is automatically reset when the heater current is less than the set value.

**Alarm setting for three-phase specification**

It becomes the amount of change with the actual amount of change of each line current.  
 \*1 For a three-phase star connection, when the (phase T) is disconnected, and the actual amount of change in the phase current decrease rate is x0.5 disconnection phase following table CT is not inserted.

The table below shows the current reduction rate when one heater is disconnected in cases where more than one heater is connected in parallel under balanced load. Use it as reference for alarm setting.

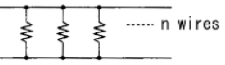
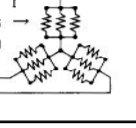
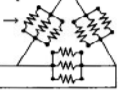
Method for connection	n=1	n=2	n=3	
1 φ 	100%	50%	33%	
3 φ star connection 	Current reduction rate of disconnected phase *1	100%	40%	25%
	Current reduction rate of other two phases	13%	8%	5%
3 φ delta connection 	Current reduction rate of the two phases connected to the disconnected heater	42%	23%	16%
	Current reduction rate of other phases	0%	0%	0%

**Cautions to take during setting**

- The load setting begins when the load voltage exceeds 20% of the rated voltage. When it is less than 20%, the alarm LP and operation LP blink alternately, keeping the standby state. The load setting shall be 50~100% of the rated voltage as much as possible.
  - When the load current exceeds approx. 6A, a setting error will occur (in terms of rated voltage). In that case, both alarm LP and operation LP come on, not beginning monitoring. Reset the load in that case so that the load current will be within the specified value.
  - When the changeover switch is kept on the automatic load setting side, the alarm LP and operation LP blink alternately in the standby state, not permitting load setting.
  - The set value will not be lost even if the power is turned off. Operation will be resumed under the same condition when the power is turned on again.
- When the setting is lost for some reason or other, the alarm enters the error state (both alarm LP and operation LP come on), not beginning monitoring. In that case, set the load again.

**Terminal connection drawing**

Single-phase

(1) FAL-100-1

AC100V 1 φ 0.5KW  
 AC200V 1 φ 1.0KW

(2) FAL-100-1

AC100V 1 φ 0.5KW or more  
 AC200V 1 φ 1.0KW or more

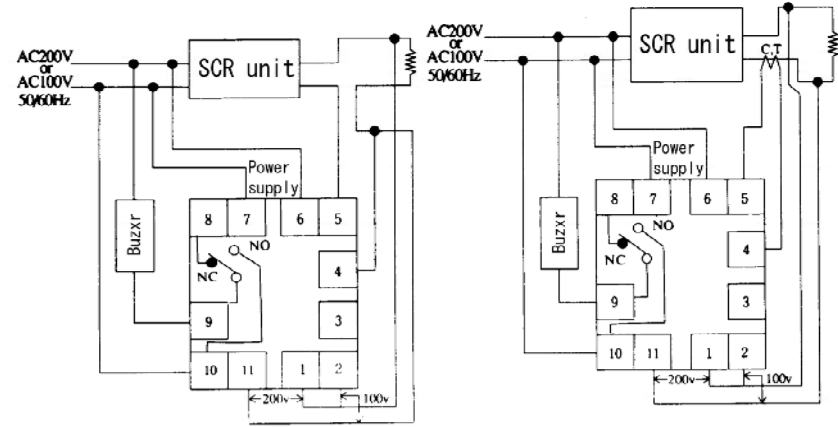

3-phase  
 FAL-100-3

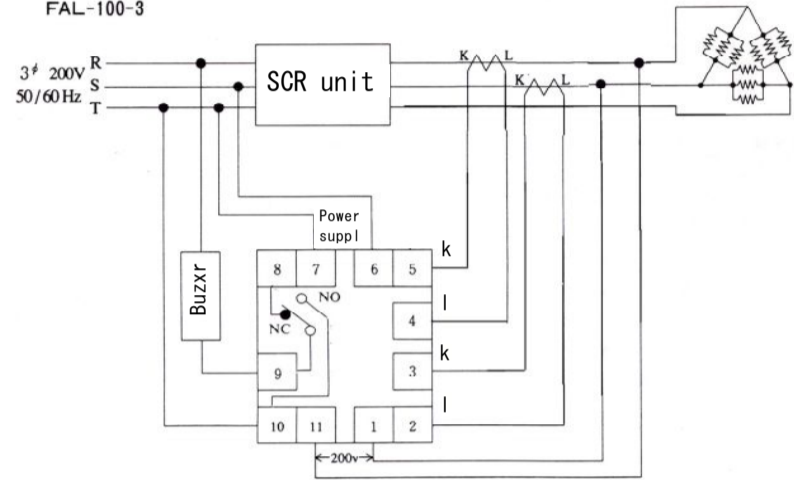

If the line current is less than 5A  
 There is no need for an external C.T.  
 The line of phase R · S phase  
 The base socket  
 Connect the series  
 Please.

**Attaching to and detaching from DIN rail**

(1) Attaching method

- Place the unit with the slider facing downward, hook it atop the DIN rail of the finger at the back of the base socket, and push it in the direction of the arrow.
- Insert the unit straight into the base socket.
- Clamp the unit with the hooks at the top and bottom of the base socket to secure the unit.

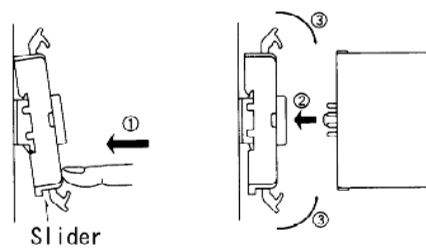

(2) Detaching method

- Remove the unit from the hooks at the top and bottom of the base socket.
- Pull the unit straight out of the base socket.
- Insert a slotted screwdriver (-) into the groove of the slider, and while pushing it down in the direction of the arrow, pull the bottom of the base socket to your side to remove it from the DIN rail.

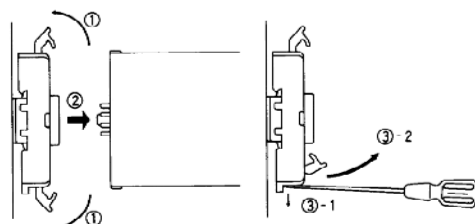

Identification mark for RoHS

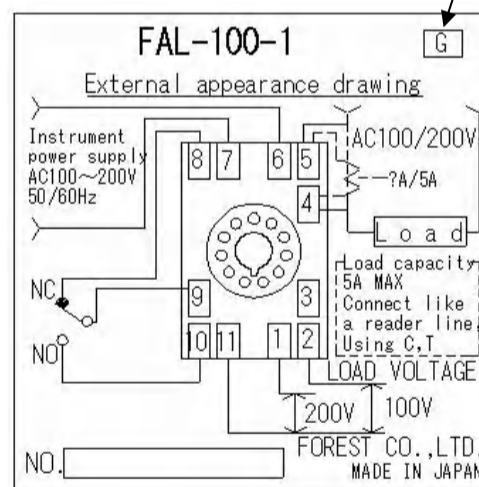

Forest Co.,Ltd.

• Head Office 4-14-15, Shimouma, Setagaya-ku, Tokyo 154-0002, Japan  
 Phone: +81 3 3421 5141 Fax: +81 3 3421 5145

• Yamanashi-Fuji Factory 1000-82, Shibokusa, Oshino-mura, Minami-tsuru-gun,  
 Yamanashi 401-0511, Japan  
 Phone: +81 555 84 2503 Fax: +81 555 84 3157

homepage <http://www.forest-ele.co.jp/>